

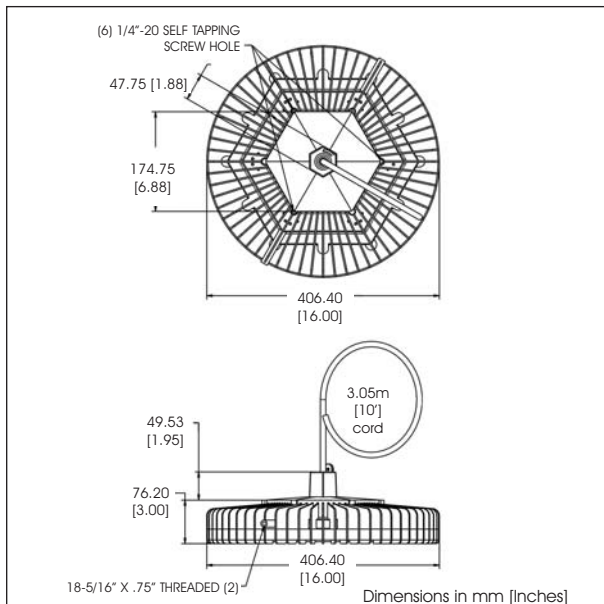

## DuroSite® Series LED High Bay Luminaire - CE Approved



### Certifications & Ratings:

- CE - compliant  
EN 55015:2006 / EN 61547:2009 / EN 60598:2008
- BS EN 62471:2008
- Gost R approval
- IEC60068 salt spray testing- severity 1
- IK10 to EN50102 (polycarbonate lens only)
- IP66 to EN60529

### Features & Benefits:

- 5 year full performance warranty
- Zone 1 hazardous area versions also available
- May be used with remote occupancy sensor
- Instant on/off operation
- Superior colour rendition index compared to HPS, LPS, MV
- Mercury free, lead free
- Replaces up to 400 Watt HID light sources
- Resistant to shock and vibration
- Temperature compensation technology for longer life
- L70 rated for 100,000 hours @ 25°C

### Order Codes:

Part Number	IP66 (Acrylic Lens)	IP66 to EN60529 <sup>2</sup> (Polycarbonate Lens)	Lens		Optical Pattern		CCT <sup>3</sup>	Initial Fixture Lumens	Lumens Per Watt <sup>4</sup>
			Clear	Diffused	Circular	Aisle			
HB2C4M-EU		•		•	•		Cool White	10,000	71
HB7C4M-EU		•		•		•	Cool White	9,750	70
HB1C4N-EU	•		•		•		Cool White	11,500	82
HB6C4N-EU	•		•			•	Cool White	11,500	82
HB0C4M-EU		•	•		•		Cool White	10,000	71
HB4C4M-EU		•	•			•	Cool White	10,750	77
HB5C4N-EU	•			•	•		Cool White	10,750	77
HB3C4N-EU	•			•		•	Cool White	10,750	77

<sup>1</sup>Part numbers in the above table include 3M PVC cable, for units including an attached junction box replace prefix **HB** with **HBJ** in the order code, **HB2C4M-EU** becomes **HBJ2C4M-EU**. For mechanical drawing see page 4.

<sup>2</sup>Circular optical pattern, polycarbonate lens part numbers can be ordered with a factory installed dome lens. For dome lens option ; replace 3rd numeral with **L**, **HB2C4M-EU** becomes **HBLC4M-EU** For mechanical drawing see page 4.

<sup>3</sup>Part numbers in the above table are cool white models, for neutral white replace the 3rd character **C** with **N** in the order code, **HB2C4M-EU** becomes **HB2N4M-EU**

<sup>4</sup>Lumens per Watt calculated based on 140W.

### Application:

The first of its kind, the Dialight DuroSite® LED High Bay luminaire was designed specifically to replace conventional lighting in a wide variety of industrial applications, both indoor and outdoor. Its low profile, light weight design and versatile mounting options make it ideal for many applications such as for many applications such as high bay lighting, warehouse, factories, cold stores, restricted access areas, service areas and other applications with mounting heights greater than 4 meters.

All of Dialight's long life LED luminaires are designed to meet the most demanding specification criteria while offering maximum energy savings, reduced maintenance costs, and a superior quality of light. Hazardous area versions are also available.

### Mechanical Information

Fixture Weight:	8.2 kg (18 lbs)
Mounting:	Swivel bracket or hook (see page 2)
Fixing <sup>1</sup> :	Factory installed 3 meter 3 core PVC cable Factory installed junction box (see ordering note, for mechanical drawing see page 4) Custom cable lengths available (consult factory)

### Electrical specifications

Operating Voltage, Input Current, Power Consumption: See Table

Operating Temp: -40°C to +65°C (-40°F to +149°F)

Harmonics: EN 61000-3-2

Surge Protection: EN 61000-4-5  
1 kV line to line  
2 kV line to ground

THD: <5% (120VAC)  
<10% (230/240VAC)  
<12% (277VAC)

Power Factor: > 0.9

### Construction

Housing:	LM6 marine grade aluminium
Finish:	Light grey powder coated (RAL7001)
Lens:	Polycarbonate (PC) Acrylic (PMMA)

### Photometric Information

CRI:	> 70
CCT:	6,000K (cool white) 4,300K (neutral white)

All values typical unless otherwise state

Operating Voltage	Input Wattage	Input Current
277	134	0.5
230	137	0.61
200	137	0.70
150	139	0.93
120	141	1.18
100	144	1.43

All measurements taken at 25°C ambient, all values +/-15%



# DuroSite® Series LED High Bay Fixture Options and Accessories

## Variable Dimming Version: 0-10 VDC



### Application:

Dialight offers a series of High Bay products with ACTIVE Dimming. Dimming permits the user to select a specific light output and power consumption to meet their requirements. The reduction in light output and power consumption are approximately proportional. Reducing the light output by 50% will reduce the power consumption by 50%. LEDs are particularly well suited for dimming as compared to other industrial light sources.

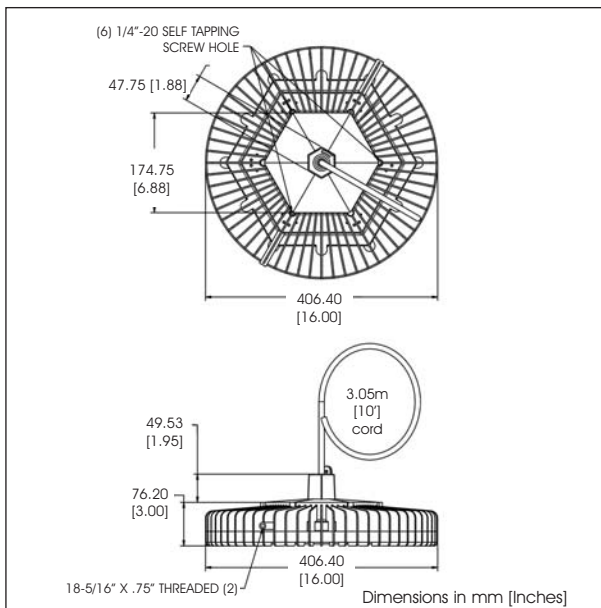

**Mechanical, Electrical and Photometric information is the same as on page 1 except where detail is provided**

**Variable Dimming Cable**<sup>1</sup>: Dimming connections included in factory installed 5 core cable. Multiple high bays can be connected to the same dimmer, consult dimming instructions and manufacturer

**Variable Dimming Control:** 0-10 VDC active

**Dimming Range** 10 VDC = 100% light output  
0 VDC = 15% light output

### Features and Benefits

- 3 meter, 5 core PVC cable pre-installed
- Dimming cabling independent of fixture wiring
- Multiple High Bays can be connected to the same dimmer
- May also be configured to operate in a single STEP Dimming configuration, please consult technical department

### STEP Dimming Mode

The variable dimming High Bays may also be configured to operate in a single STEP Dimming configuration. When the dimming control conductors are connected together, the light output will be reduced to approximately 15% of the maximum light output. The total fixture power consumption will also be reduced to approximately 20% (30 W). Connecting the leads together can be accomplished with a common wall switch.

### Order Codes:

Part Number	IP66 (Acrylic Lens)	IP66 to EN60529 <sup>2</sup> (Polycarbonate Lens)	Lens		Optical Pattern		CCT <sup>3</sup>	Initial Fixture Lumens	Lumens Per Watt <sup>4</sup>
			Clear	Diffused	Circular	Aisle			
HB2C4M-EUD		•		•	•		Cool White	10,000	71
HB7C4M-EUD		•		•		•	Cool White	9,750	70
HB1C4N-EUD	•		•		•		Cool White	11,500	82
HB6C4N-EUD	•		•			•	Cool White	11,500	82
HBOC4M-EUD		•	•		•		Cool White	10,000	71
HB4C4M-EUD		•	•			•	Cool White	10,750	77
HB5C4N-EUD	•			•	•		Cool White	10,750	77
HB3C4N-EUD	•			•		•	Cool White	10,750	77

<sup>1</sup>Part numbers in the above table include 3M PVC cable, for units including an attached junction box replace prefix **HB** with **HBJ** in the order code, **HB2C4M-EUD** becomes **HBJ2C4M-EUD**. For mechanical drawing see page 4.

<sup>2</sup>Circular optical pattern, polycarbonate lens part numbers can be ordered with a factory installed dome lens. For dome lens option ; replace 3rd numeral with **L**, **HB2C4M-EU** becomes **HBLC4M-EU** For mechanical drawing see page 4.

<sup>3</sup>Part numbers in the above table are cool white models, for neutral white replace the 3rd character **C** with **N** in the order code, **HB2C4M-EUD** becomes **HB2N4M-EUD**

<sup>4</sup>Lumens per Watt calculated based on 140W.

# DuroSite® LED High Bay Fixture Options and Accessories

## Occupancy Sensor Version

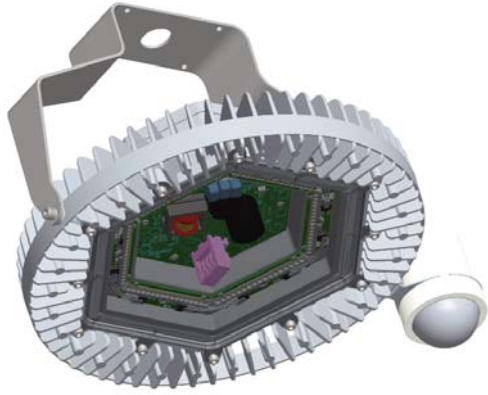

### Application:

Dialight offers a series of High Bay products with an attached occupancy sensor. The occupancy sensor leverages the High Bay's instant-on and instant-off capability to increase energy savings and enhance ROI. Other industrial lighting sources such as HID fixtures do not offer instant-on capability. Sensor can be programmed by the user during installation and commissioning via a IR remote control (sold separately), one remote can program an infinite number of luminaires.

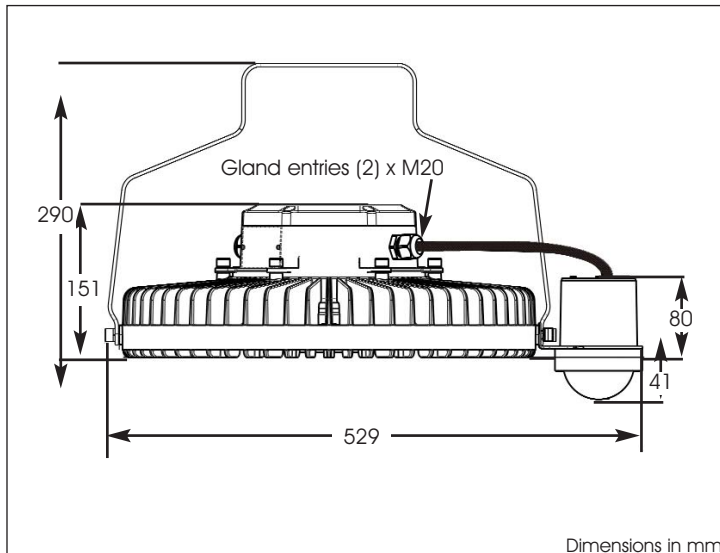

**Mechanical, Electrical and Photometric information is the same as on page 1 except where detail is provided**

- Weight:** 8.6kg (19lbs)
- Sensor Mounting:** Attached to the luminaire via a bracket, cable connected via junction box on the luminaire
- Sensor Timing** 30 seconds to 20 minutes
- Sensor operation** Dependant on application and height, please consult technical department
- Operating voltage** 230/240 VAC only
- Operating Temperature** -10°C + 65°C (-14°F + 149°F)
- Features and Benefits**
  - No additional electrical connections required for installation
  - Remote control for on site programming during commissioning

### Ordering Info:

Part Number	Description
HBX-RF	IR remote control

Part Number	IP66 (Acrylic Lens)	IP66 to EN60529 <sup>1</sup> (Polycarbonate Lens)	Lens		Optical Pattern		CCT <sup>2</sup>	Initial Fixture Lumens	Lumens Per Watt <sup>3</sup>
			Clear	Diffused	Circular	Aisle			
HBJ2C4M-EUOS		•		•	•		Cool White	10,000	71
HBJ7C4M-EUOS		•		•		•	Cool White	9,750	70
HBJ1C4N-EUOS	•		•		•		Cool White	11,500	82
HBJ6C4N-EUOS	•		•			•	Cool White	11,500	82
HBJ0C4M-EUOS		•	•		•		Cool White	10,000	71
HBJ4C4M-EUOS		•	•			•	Cool White	10,750	77
HBJ5C4N-EUOS	•			•	•		Cool White	10,750	77
HBJ3C4N-EUOS	•			•		•	Cool White	10,750	77



<sup>1</sup>Circular optical pattern, polycarbonate lens part numbers can be ordered with a factory installed dome lens. For dome lens option ; replace 3rd numeral with **L**, HB2C4M-EU becomes HBLC4M-EU For mechanical drawing see page 4.

<sup>2</sup>Part numbers in the above table are cool white models, for neutral white replace the 3rd character **C** with **N** in the order code, HB2C4M-EUOS becomes HB2N4M-EUOS

<sup>3</sup>Lumens per Watt calculated based on 140W.

# DuroSite® Series LED High Bay Fixture

## Accessories

	Part Number	Description	Kit Includes
	HBXW3	Swivel Bracket Grey (RAL7001) powder coated aluminium (Interior or exterior use)	Swivel Bracket Bracket to fixture hardware
	HBXH	Hook (IP40)	Hanger Hook (Factory fitted option)
	HBXGS	Glare Shield - sets of 10 Grey (RAL7001) powder coated spun aluminium (Interior use only, for use with flat lens options)	Aluminium shield and securing hardware

## Mechanical Drawings

HBXX4X - Junction Box

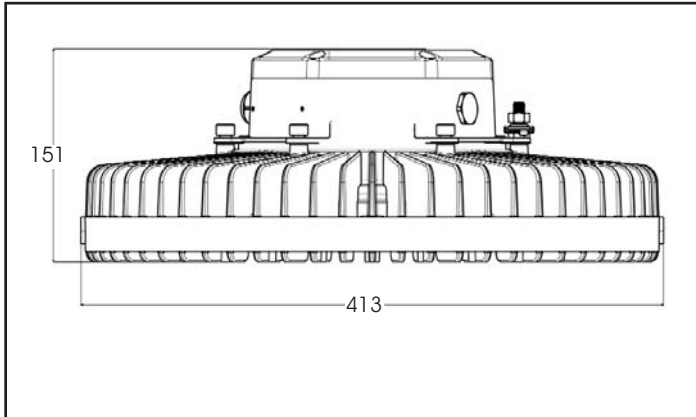

HBLXX4X - Dome Lens

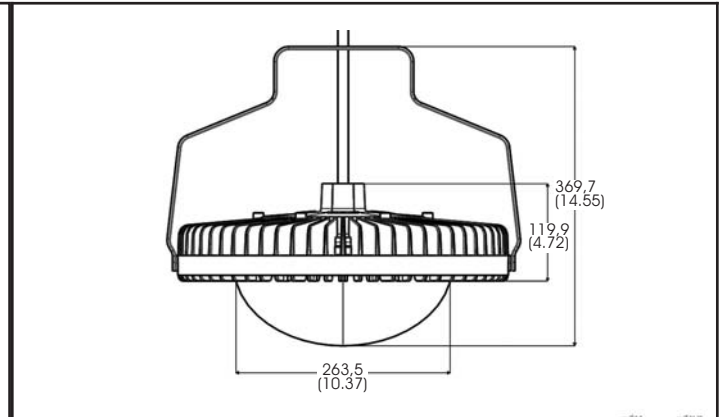

HBXW3 - Swivel Bracket

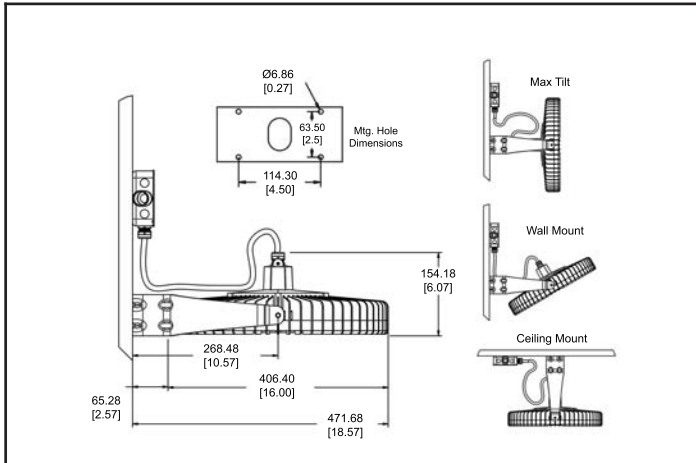

HBXX4X-EU

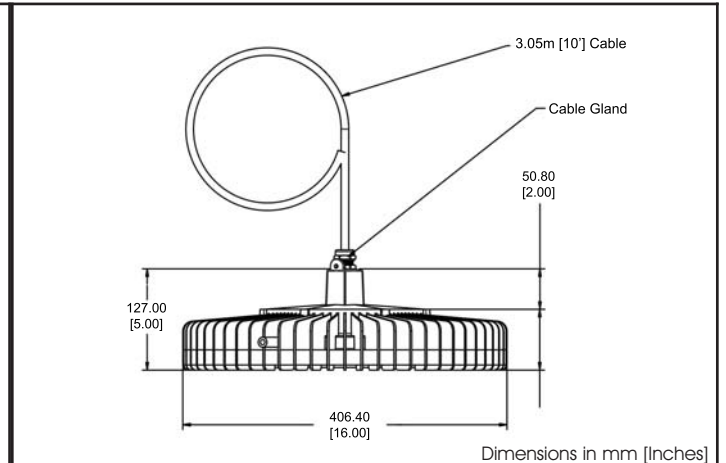

## Polar Plots

Circular Pattern

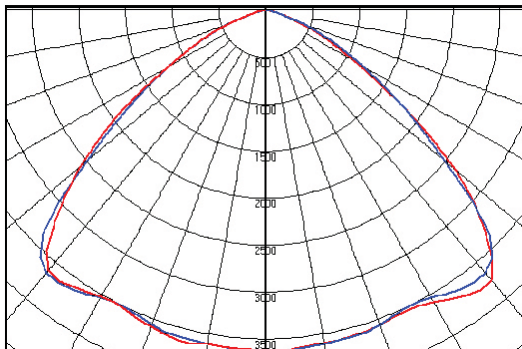

Aisle Pattern

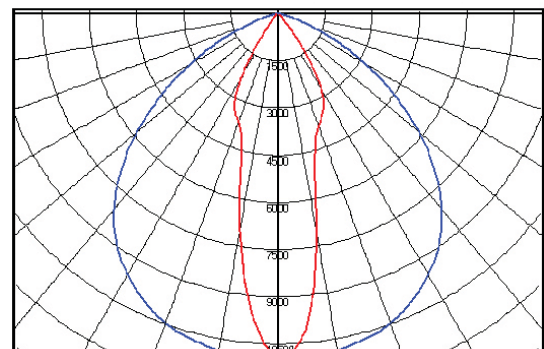

Dialight reserves the right to make changes at any time in order to supply the best product possible. The most current version of this document will always be available at: [www.dialight.com/Assets/Brochures\\_And\\_Catalogs/Illumination/MDEXHBEU001.pdf](http://www.dialight.com/Assets/Brochures_And_Catalogs/Illumination/MDEXHBEU001.pdf)